

Lab 4: Instrumentation
Amplifier

YOUR NAME:

YOUR SID:

YOUR PARTNER'S NAME:

YOUR PARTNER'S SID:

STATION NUMBER:

LAB SECTION:

Pre-Lab GSI Sign-off

Pre-Lab Score: ___/40

In-Lab Score: ___/60

Total: ___/100

Instrumentation Amplifier

LAB 4: Instrumentation Amplifier

ELECTRICAL ENGINEERING 43/100

INTRODUCTION TO MICROELECTRONIC CIRCUITS

University Of California, Berkeley

Department of Electrical Engineering and Computer Sciences

Professor Kris Pister

Lab Contents:

- I. Lab Objectives
- II. Pre-Lab Component
 - a. Strain Gauges
 - b. The Wheatstone Bridge
 - c. The Instrumentation Amplifier
- III. Lab Component
 - a. The Instrumentation Amplifier
 - b. Why do we care?
- IV. Lab Report Submissions
 - a. Image Citations

Lab Objectives

In the previous lab, we learned about operational amplifiers and how to implement basic configurations such as the amplifiers, Schmitt triggers, and comparators. Now that you are familiar with operational amplifiers, we will build a sensor interface which is one of the most common applications of operational amplifiers.

Also in this lab you will be introduced to the strain gauge, which is a variable resistor that increases or decreases in resistance based on the physical mechanical stress applied to it. The strain gauge you will use is attached to a metal bar, so you can put weights on the bar to bend it. This will cause the strain gauge to stretch and hence warp the dimensions of the variable resistor and its resistance. To measure this change in resistance, you will use a wheatstone bridge configuration in conjunction with an instrumentation amplifier.

Prelab

Pre-Lab Assignment

1. Read lectures notes on amplifiers posted on Piazza.
2. Complete the prelab questions over the next few pages (**40 points**).
3. Familiarize yourself with the rest of this document before arriving in lab!
4. Watch the online lab lecture videos related to this lab. It may help to watch them before you attempt the pre-lab questions.
5. Rewatch the online lab videos for the lab equipment including those on the solderless breadboard, oscilloscope, power supply, and function generator.
6. Optional: Built and simulate the instrumentation amplifier in Multisim.

Strain Gauges

A strain gauge operates on the principles that physical strain deforms the physical dimensions of a material. We know from physics that resistance is proportional to the length of the material, and inversely proportional to the width given by the following equation:

$$R = \rho l / A \text{ where } A = wh$$

When we deform the strain gauge resistor, we either increase the length l and decrease the area A , thus increasing resistance, or we decrease the length and increase the area A , decreasing resistance. Therefore the strain gauge is a **variable resistor** represented as a resistor with an arrow as shown below.



Variable Resistor Circuit Symbol¹

The Wheatstone Bridge

To convert the change in resistance of the strain gauge into a voltage output, we use a wheatstone bridge circuit. The three resistors in this circuit have the same resistance as the nominal (unstrained) value of the strain gauge, so its output is approximately proportional to the change in resistance ΔR .

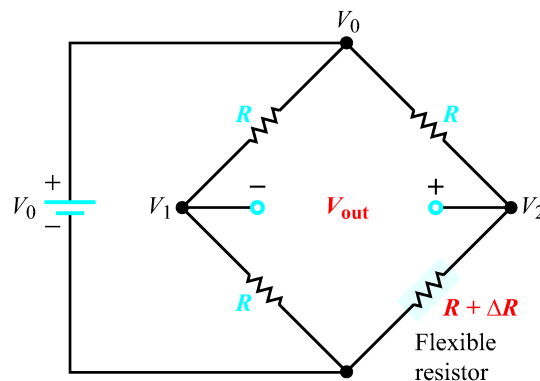

Figure 2-32: Circuit sensor.¹

for Wheatstone-bridge

For the above diagram of the wheatstone bridge, show that the following relationship in an ideal case is true:

$$V_{out} \cong \frac{V_0}{4} \left(\frac{\Delta R}{R} \right)$$

Hint: use the voltage divider equation to solve for nodes V_1 and V_2 , and solve for V_{out} . Assume: $\Delta R \ll R$

Score: __/10

Unfortunately, in the lab it is almost impossible to have a perfect wheatstone bridge that we can interface the strain gauge to without some adjustments. The main problem is resistor tolerance as was discussed in the resistors lab. Recall that resistor tolerance falls in the range of $\pm 5\%$ and the voltage difference we want to measure is given by two voltage dividers. In addition, the relative change in resistance that we want to observe is very small and on the order of 0.1%.

¹ Ulaby and Maharbiz, Circuits. Figure 2-32

This means that if we arbitrarily choose some $\pm 5\%$ resistors, we will have some difference V_{offset} already before we apply strain to get the voltage change due to the variable resistor dV . Clearly V_{offset} can be much greater than dV so we need to somehow eliminate V_{offset} otherwise after we apply the gain G to the difference, we will get $G \times (V_{offset} + dV)$ when we really want $G \times dV$. This is especially problematic when V_{offset} is so large that $G \times (V_{offset} + dV)$ is greater than maximum voltage the amplifier can handle (e.g., one of the voltage rails), in which case the dV will not be discernible at the output at all.

To solve this problem, you are going to have to add a floating supply voltage to the wheatstone bridge. This can be done with the 6V HP E3631A power supply as shown on the left. Note that depending on the polarity of V_{offset} , the $+/-$ terminals may need to be reversed from those shown in the figure.

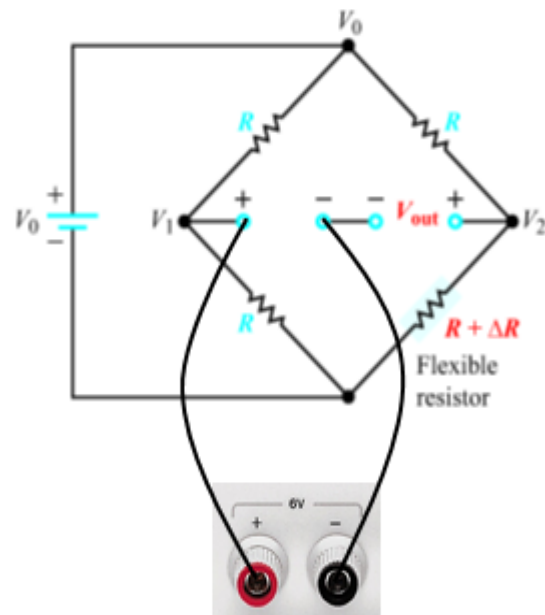

The Instrumentation Amplifier

The bridge circuit gives us a way to measure the change in resistance of the strain gauge. One of the problems with using strain gauges is that the changes in resistance are on the order of 10^{-5} so they are very difficult to detect. The solution to this problem is to use a high gain operational amplifier to detect changes in the voltage levels such as an instrumentation amplifier.

For more info please read: http://en.wikipedia.org/wiki/Instrumentation_amplifier

Figure 4-20 on page 6 shows the implementation of the instrumentation amplifier. We want to derive the output voltage (V_o) as a function of the input voltage ($V_2 - V_1$). To do this, we can break it up into two simpler amplifier stages and solve each individually.

The following circuit is the first stage, known as the buffer stage of the Instrumentation Amplifier. Using the assumptions for ideal operational amplifiers, solve the circuit to find $V_{o2} - V_{o1}$ in terms of $V_2 - V_1$. Show that the gain of this circuit ($(V_{o2} - V_{o1}) / (V_2 - V_1)$) is:

$$v_{o2} - v_{o1} = \left(\frac{R_1 + R_2 + R_3}{R_2} \right) (v_2 - v_1)$$

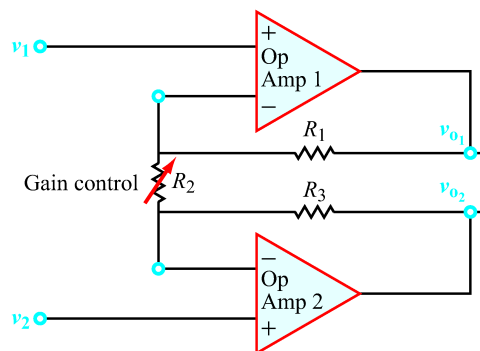

Score __/5

The next circuit is the second stage, known as the amplification stage of the Instrumentation Amplifier is built using a standard differential amplifier circuit. For more info:

http://en.wikipedia.org/wiki/Operational_amplifier_applications_-_Differential_amplifier

Using the assumptions for ideal operational amplifiers, solve this circuit to find v_o in terms of $v_{o2} - v_{o1}$. Show that the gain of this circuit is:

$$v_o = \left(\frac{R_4}{R_5}\right)(v_{o2} - v_{o1})$$

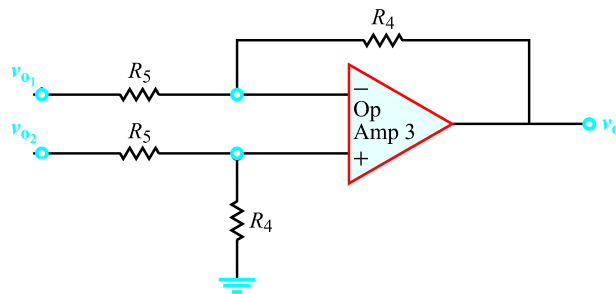

Score __/10

Now we can put the two stages together to get the full Instrumentation Amplifier. Using your previous two results, derive the following relationship between the input voltages and the output voltage:

$$v_o = \left(\frac{R_1 + R_2 + R_3}{R_2} \right) \left(\frac{R_4}{R_5} \right) (v_2 - v_1)$$

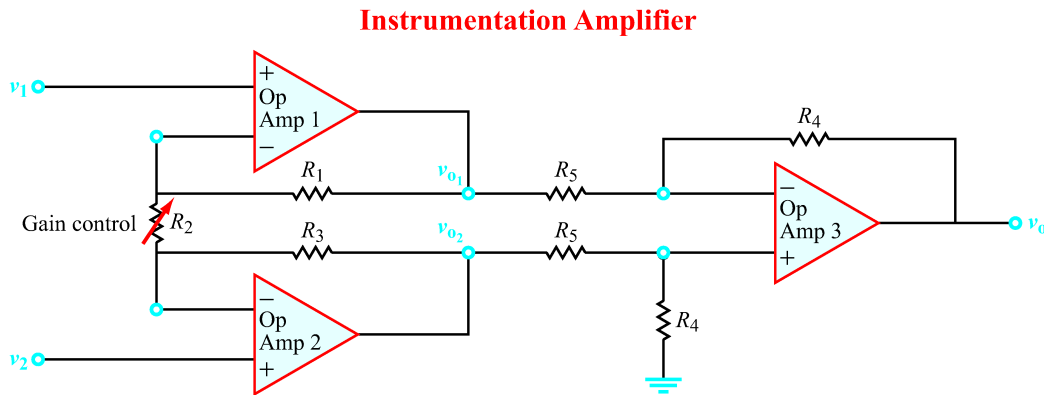

Figure 4-20: Instrumentation amplifier circuit.²

Score __/5

² Ulaby and Maharbiz, Circuits. Figure 4-20

To make your lab time more efficient, you will plan out your breadboard layout as part of this prelab. Below is a diagram of a breadboard similar to the one handed out as part of your kit. Draw in the required components (e.g., strain gauge terminals, bridge circuit, amplifier stages, etc.) so that you can simply copy this plan when you build the actual circuit. Use good breadboard etiquette (as few wires as possible, no long wires, etc.) and note that you only need to use 2 op-amp chips to build the 3 op-amps in the instrumentation amplifier. Use dotted lines to delineate the different circuit stages (i.e., bridge, amp stage 1, amp stage 2).

Score __/10

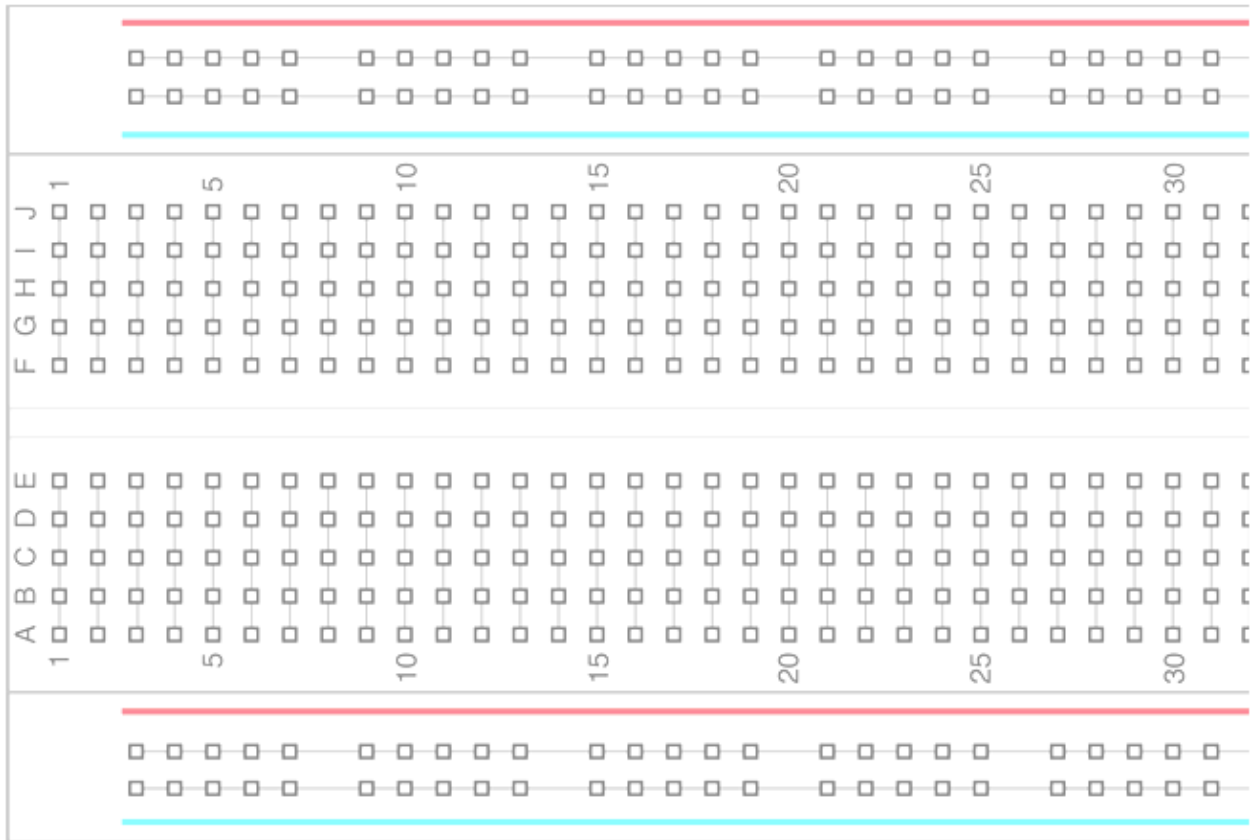

Lab Section

The Instrumentation Amplifier

Recall that the purpose of the wheatstone bridge circuit is to determine small differences in resistance through voltage measurements. Build the bridge circuit using a strain gauge as the variable resistor and connect it to a 5V supply from the E3631A power supply. Choose your other three resistances that have approximately the same value of resistance as the strain gauge. You will need to measure the resistance of the strain gauge, without any added weight, using the HP 34401A multimeter.

Score ___ / 5

Strain Gauge Resistance: _____

Resistance Value of Three Other Resistors: _____

Ideally, without added weight on the strain gauge, the output of the wheatstone bridge will be 0 V. Due to resistance tolerance this won't necessarily be true. You will have to apply a DC offset to zero the output voltage (get it to within 1mV of 0V) before proceeding further, using the configuration shown in the prelab.

BEFORE building the amplifier, TEST your bridge circuit with the HP 34401A multimeter. You should see an output that clearly increases when the strain gauge is flexed one way and clearly decreases when flexed the other way. If you are having problems getting this to work, ASK YOUR TA BEFORE MOVING ON!

Next, build the instrumentation amplifier. Determine suitable resistances such that your circuit will have a **gain between 300 and 1000**. It is a good idea to have some gain in both stages of the amplifier. The voltage you want to amplify is the output of the wheatstone bridge, so you will want to connect that as the input to the instrumentation amplifier.

The final circuit you build, with the output of the wheatstone bridge connected to the input of the instrumentation amplifier, which itself requires three op amps, will be sufficiently complicated that debugging after building will be very difficult. Therefore, it is of the utmost importance that you **test and verify** each step along the way, so there are no surprise failures at the end. Separate the circuit into small, testable sub-circuits. The wheatstone bridge can be tested on its own as described above. The instrumentation amplifier can be tested on its own, without the bridge. The instrumentation amplifier can be broken down further, as you can test the buffer stage of two op amps independently from the final amplification op amp. Patiently testing each sub-circuit along the way can save a lot of headache and time at the end.

In the space provided on the next page:

- State what resistances you chose to use for the instrumentation amplifier and why you chose those values.
- Compute the theoretical gain of the instrumentation amplifier that you built using your resistor values.
- Measure the **actual** gain of the amplifier. This can be easily done by changing the voltage introduced with the 6V power supply and comparing it to the final output voltage. Explain the discrepancy between theoretical gain and actual gain, if it exists.

Score __/15

$R_1 =$ $R_2 =$ $R_3 =$ $R_4 =$ $R_5 =$

Computed Theoretical Gain =

Measured Actual Gain =

Now take the appropriate measurements to determine the change in resistance of your strain gauge caused by the addition of a 200g, 400g, and 600g weight at the end of the gauge. For each weight, include the final output voltage change and the calculated resistance change of the strain gauge. Explain all necessary measurements and calculations. Make sure you use the **actual** gain of the amplifier that you measured in the last step.

Score __/10

Weight	V_o [Measured]	ΔR
0		
200g		
400g		
600g		

Show your wheat stone bridge connected to your instrumentation amplifier to your lab GSI for check off and demonstrate a reasonable change in voltage when you apply weights to the strain gauge. Your initial configuration should output as close to zero as possible.

Your GSI Signs Here (30 pts)

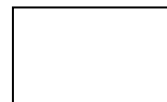

Why do we care?

Instrumentation amplifiers are designed to have extremely high gains and are usually preferred over stand-alone amplifiers due to noise and interference considerations.

For our EEG final project, we will be dealing with extremely low level microvolt signals. In order to achieve the necessary gains to detect that kind of signal, we will have to use a high gain instrumentation amplifier in order to process the signal.

We will be building the instrumentation amplifier from discrete parts for your final project as you did for this lab so it would be a good idea to take a look at your working implementation and note it for the final project.

Lab Report Submissions

This lab is **due at the beginning** of the next lab section. Make sure you have **completed all questions** and **drawn all the diagrams** for this lab. In addition, attach any loose papers specified by the lab and submit them with this document.

These labs are designed to be completed in **groups of two**. Only one person in your team is required to submit the in-lab report. However, the **pre-lab section** should be done **individually**. Make sure the names and student IDs of **BOTH** team members are on this document (preferably on the front).

Image Citations

Textbook Images are courtesy of Fawwaz T. Ulaby and Michel M. Maharbiz and National Technology and Science Press.

Fawwaz T. Ulaby and Michel M. Maharbiz, Circuits © 2009 National Technology and Science Press

ⁱ <http://www.clker.com/clipart-24578.html>